

ING SEGNALETICA SIGN SIGN BESCHILDERUNG SEGNALETICA SIGN
A BESCHILDERUNG SIGN SEGNALETICA BESCHILDERUNG SIGN
ALETICA BESCHILDERUNG SIGN SEGNALETICA BESCHILDERUNG

SIGNCODE[®]
TO BE UNIQUE WITH OUR SIGN

patented



SISTEMA DI SEGNALETICA & INFORMAZIONE
BESCHILDERUNGSSYSTEM & INFORMATION
SIGN SYSTEM & INFORMATION

**Amministrazione
Lorenzo Altini**

2.1



patented

SIGNCODE® THE NEW SIGNAGE LINE. THE BEST SOLUTION FOR PERFECT SIGNAGE.



ADVANTAGE 1

QUALITY & SERVICE

WE AT KUNSTDÜNGER ATTRIBUTE GREAT VALUE TO QUALITY.

IT | questo si riflette da un lato nella realizzazione, nel ruolo e nella lavorazione dei nostri prodotti e dall'altro nella collaborazione con i nostri clienti. kunstdünger consegna in 80 paesi in tutto il mondo. la nostra gestione dei progetti con consulenza, pianificazione, sviluppo e montaggio è apprezzata da più di 18 anni nel mercato della comunicazione visiva.

DE | das spiegelt sich zum einen in der gestaltung, funktion und verarbeitung unserer produkte wieder, und zum anderen in der partnerschaftlichen zusammenarbeit mit unseren kunden. kunstdünger liefert in über 80 länder der erde. unsere projektentwicklung mit beratung, planung, gestaltung und montage wird im beschilderungsmarkt seit mehr als 18 jahre geschätzt.

EN | this is reflected on one hand by the realization, in its role and in the workmanship of our products, and on the other in the collaboration with our clients. kunstdünger delivers to 80 countries worldwide. our project consulting management, planning, development and installation has been appreciated for more than 18 years in the signage and information market.

ADVANTAGE 3

DESIGN FOR ANY ENVIRONMENT

SIGNCODE IS DIFFERENT. THIS IS REFLECTED IN THE EXTRAORDINARY DESIGN.

IT | sia per l'esterno che per l'interno, kunstdünger utilizza lo stesso linguaggio e la stessa qualità di materiali. profili di alluminio anodizzato di alta qualità vengono trasformati in pannelli singoli oppure in sistemi direzionali e di orientamento. il design caratteristico degli angoli signcode conferisce a questo sistema di segnaletica un carattere unico ed inconfondibile.

DE | sowohl im innen- als auch im außenbereich setzt kunstdünger auf die gleiche formensprache und materialanmutung. hochwertige, silber eloxierte aluminiumprofile werden zu einzelschilder oder leit- und orientierungssysteme verarbeitet. die signcode-typischen designecken verleihen diesem schildersystem sein unverwechselbares aussehen.

EN | whether for indoors or outdoors, kunstdünger uses the same language and the same quality of materials. high quality anodized aluminium are transformed into single panels or way finding systems. the design of signcode is characterized by the corners, giving this signage system a unique and unmistakable character.

ADVANTAGE 2

UNLIMITED POSSIBILITIES

SIGNCODE OFFERS A FULL RANGE FOR WALL, CEILING, FLAG AND FOR OUTDOOR PANELS.

IT | nel caso di informazioni che vadano aggiornate frequentemente, signcode è la prima scelta. un pannello in acrilico antiriflesso protegge le informazioni stampate su carta signcode. per la stampa di informazioni permanenti in serigrafia, stampa digitale, stampa diretta su un materiale in alta qualità, la protezione in acrilico viene sostituita da un pannello in alluminio stampabile. signcode-color porta il colore nei suoi progetti di segnaletica.

DE | bei häufiger aktualisierung von informationen ist signcode die erste wahl. eine reflexfreie acrylscheibe schützt die beschriftungseingleger aus signcode-paper. für dauerhafte beschriftung im siebdruck, digitaldruck, direktdruck oder mit weiser hochleistungsfolie wird die acrylscheibe durch ein beschriftbares aluminiumpaneel ersetzt. signcode-color bringt farbe in ihr beschilderungsprojekt.

EN | in those instances where information needs to be updated regularly, signcode is the first choice. a non reflecting acrylic panel protects the information printed onto signcode paper. for permanent prints with screen printing, digital printing or direct printing onto high quality material, the acrylic protection is substituted with a printable aluminium panel. signcode colour brings colour to your signage projects.

ADVANTAGE 4

THE PATENTED SPRING CLOSING SYSTEM

WITH THE HELP OF THE KEY YOU CAN CHANGE INFORMATION IN A FEW SECONDS.

IT | la chiusura a molla brevettata di signcode protegge i suoi cartelli da accessi non autorizzati. con l'aiuto della chiavetta si possono cambiare le informazioni in pochi secondi. signcode rende possibile anche la realizzazione di pannelli speciali come la segnaletica di sicurezza, indicazione delle vie di fuga e segnaletica per non vedenti.

DE | der patentierte signcode-federverschluss schützt ihre schilder vor unbefugten zugriff. mittels systemschlüssel erfolgt der informationswechsel in sekundenschnelle. auch sonderbeschilderung wie sicherheitskennzeichnung, fluchtwegbeschilderung und beschilderung für sehbehinderte und blinde sind mit signcode möglich.

EN | the patented spring closing system protects your panels from unauthorized access. with the help of the key you can change information in a few seconds. signcode gives you the possibility to make special panels such as those for security, emergency exit indications and signage for visually impaired people.

VISIONE GENERALE | A SCELTA LIBERA
PRODUKTÜBERSICHT | FREI WAHL
OVERALL VIEW | FREE CHOICE

IT | le soluzioni innovative che sviluppiamo per i nostri clienti, costituiscono la base per le idee per i nuovi prodotti, che vi presentiamo con questo catalogo. sono disponibili diverse possibilità di applicazione della linea di prodotti signcode sia nell'ambito della segnaletica per interni che in quella per esterni.

DE | innovative lösungen, die wir für unsere kunden entwickeln, bilden die grundlage neuer produktideen, deren spektrum wir ihnen mit diesem katalog vorstellen. verschiedene anwendungsmöglichkeiten der signcode produktionslinie im bereich der innen-und außenbeschilderung stehen zur auswahl.

EN | the innovative solutions that we develop for our clients, constitute the basis for ideas for new products, which we are presenting to you in this catalogue. there are different application possibilities of the signcode range, both for internal and external signage. this variety will be useful to help choose the most adapt solution for your needs or environment.

PAGE 4

SIGNCODE® eXtern

IT | una perfetto sistema di segnaletica si vede in primo luogo da come le indicazioni collocate all'esterno accolgono i visitatori.

DE | zu einem perfekten wegleitsystem gehört bereits der empfang im aussenbereich.

EN | perfect signage welcomes visitors already to the outdoor area.

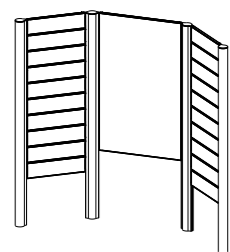

PAGE 6-11

patented

SIGN FOR ORIENTATION

IT | dal fuoriporta alla segnaletica autoportante, le forme chiare ed eleganti caratterizzano tutti gli elementi della linea signcode.

DE | vom türschild bis zum aufsteller, die klare und elegante form charakterisiert alle elemente der signcode linie.

EN | from door signs to free standing signs, the elegant and clear looks characterize all of the elements of the signcode range.

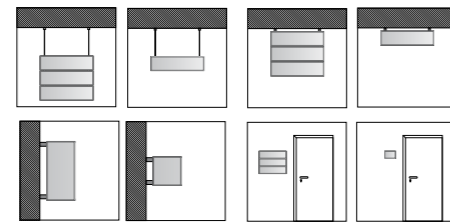

PAGE 12

patented

SIGNCODE® COLOR

IT | l'innovativa segnaletica signcode colors offre un sistema direzionale a colori integrato nella cornice sui lati verticali o, nelle applicazioni a bandiera, su quelli orizzontali.

DE | das beschilderungssystem signcode colors bietet exclusiv ein rahmenintegriertes farbleitsystem der vertikalen bzw. bei fahnnenschilder der horizontalen seiten.

EN | the innovative signage system signcode colors offers you a directional system with colours integrated into the frame.



PAGE 14

SIGNCODE® SECURE

IT | segnaletica a parete completa di pittogrammi e angoli e cornici verticali del colore corrispondente al pittogramma stesso, per uso interno.

DE | fertige wandbeschilderung mit sicherheitsmotiven und passender rahmen- farbkennung für den innenbereich.

EN | ready made wall signage with security images and matching frame colours for indoor use.



PAGE 16

SIGNSHINE®

IT | segnaletica di sicurezza luminescente di lunga durata unita all'intelligente sistema signcode. signshine offre vari motivi realizzati su pvc fotoluminescente.

DE | nachleuchtende sicherheitsbeschilderung mit dem intelligenten signcode system. signshine bietet diverse motive auf nachleuchtendem pvc.

EN | after glow security signage with the intelligent signcode system. signshine offers many different images on photoluminescent pvc panels.



PAGE 18

SIGNCODE® IN-OUT

IT | chiarezza a colpo d'occhio, informazione immediata, per sapere se una sala è occupata o libera... tutto ciò è possibile grazie a signcode in-out!

DE | mit einem blick klarheit, ob ein raum frei ist oder belegt ist? signcode in-out macht's möglich!

EN | understand immediately if a room is free or not? signcode in-out can give you that information just with one slight move by the hand.



PAGE 19

SIGNCODE® BRAILLE

IT | offriamo anche una segnaletica in braille con simboli in rilievo, integrata nei nostri pannelli signcode e signcode color.

DE | beschilderung mit braille-schrift und tastbaren symbolen verwirklichen wir gerne für ihr projekt.

EN | we realize also signage with braille and palpable symbols for your projects.



DIAMO VITA AL TUO AMBIENTE.

WIR BRINGEN LEBEN IN IHR AMBIENTE.

WE BRING LIFE TO YOUR ENVIRONMENT.

SIGN

FOR YOU

- 1 guida principale per esterno
hauptwegweiser für aussenbereich
principal guider for outdoor use
- 2 identificazione aziendale
firmenschild/gebäudeidentifikation
company symbol / company identification
- 3 segnaletica direzionale autoportante
etagenübersicht freistehend
freestanding sign
- 4 espositore da tavolo
tischaufsteller
table top display
- 5 segnaletica a bandiera
infoschild fahne
flag signage
- 6 segnaletica a parete
wegweiser wand
wall panel
- 7 pannello fuoriporta
türschild
door sign
- 8 pannello a soffitto
wegweiser decke
ceiling sign
- 9 segnaletica di sicurezza a parete
sicherheitsschild wand
wall safety signage
- 10 segnaletica di sicurezza a bandiera
hinweisschild fahne
flag signage indication
- 11 segnaletica a muro
hinweisschild wand
wall signage indication
- 12 segnaletica direzionale a parete
etagenübersicht wand
wall plans

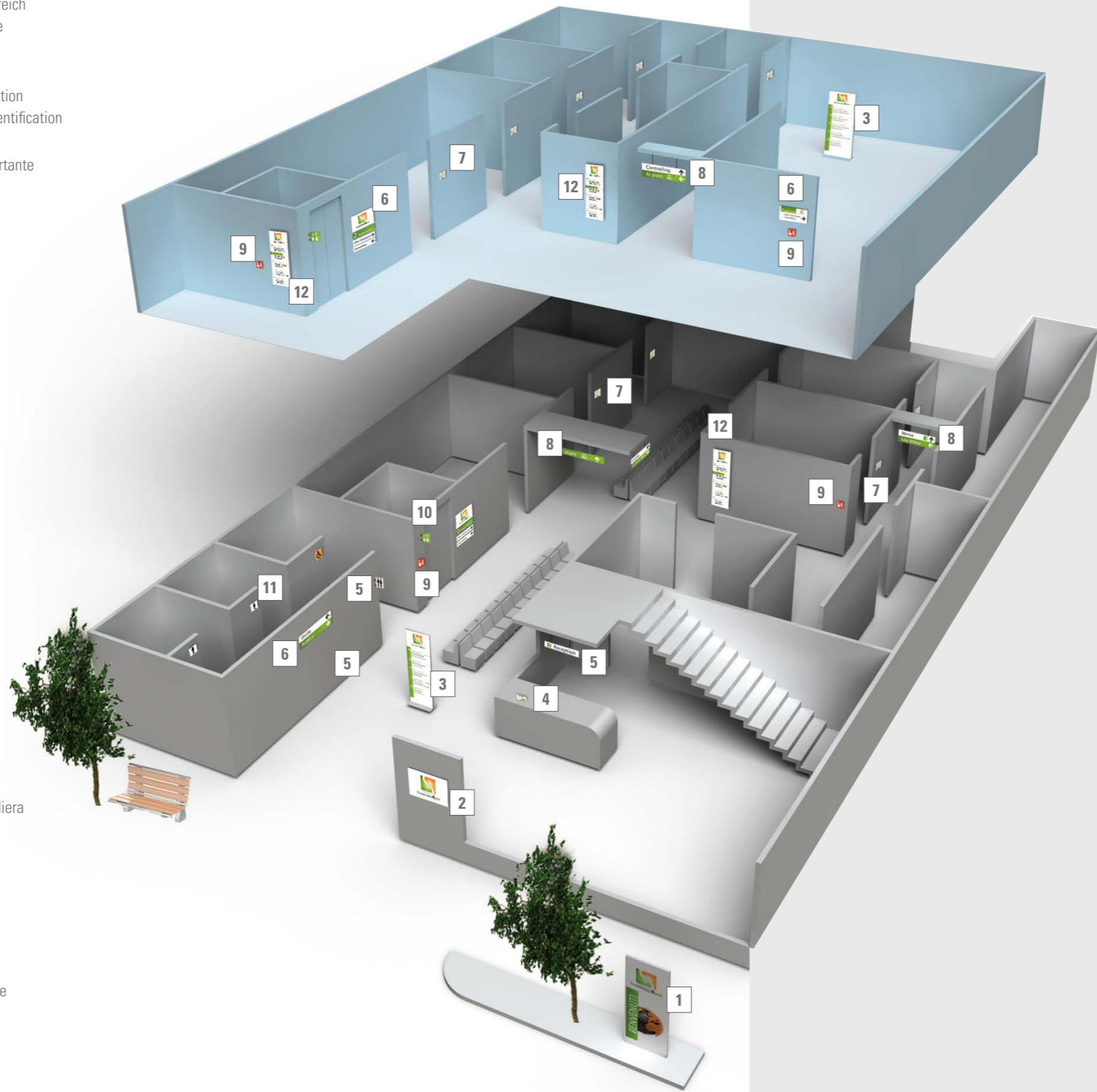

complete solution with style.
one design for all areas.

IT | dal fuoriporta alla segnaletica, le forme chiare ed eleganti caratterizzano tutti gli elementi della linea signcode. sia come segnaletica a soffitto, a bandiera oppure come planimetria, signcode presenta le informazioni in maniera sempre accattivante. i materiali, la lavorazione tecnica e la preparazione garantiscono una lunga durata e trasformano il cartello in un inconfondibile porta informazioni ad altissima individualità.

DE | vom eingangsbereich bis in den letzten stock: klare und elegante formen charakterisieren alle elemente der signcode linie. decken-, fahnen- und freistehende beschilderung ist mit signcode stets informativer blickfang. materialien, technische ausführung und verarbeitung gewährleisten eine hohe haltbarkeit und verwandeln ihr schild in einen unverwechselbaren informationsträger mit hoher individualität.

EN | from door signs to free standing signs, the elegant and clear looks characterize all of the elements of the signcode range. whether it's a ceiling, a flag or signage plan, signcode presents the information in a simple but attractive way. the material, technical elaboration and preparation guarantee a long duration and transforms the sign into an unmistakable information carrier of the highest standards.

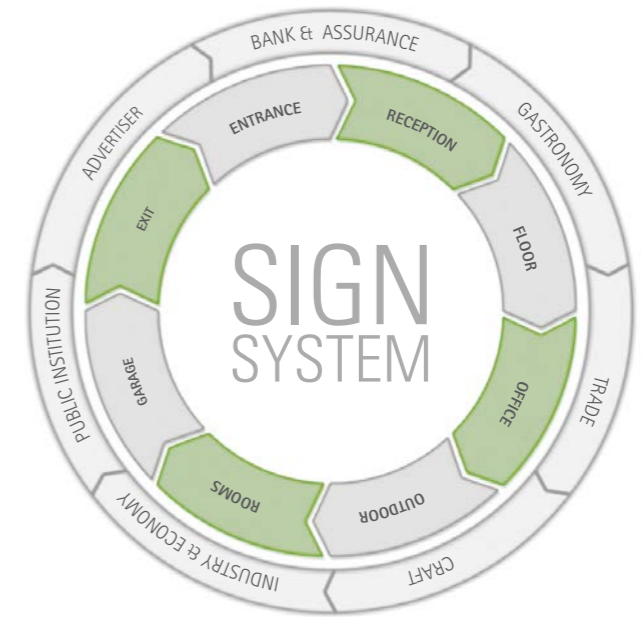

INDUSTRIE & AREE DI APPLICAZIONE
BRANCHEN & ANWENDUNGSBEREICHE
INDUSTRY & APPLICATION AREA



outdoor signage system.
first impressions count. well thought out and very singular.

IT | una perfetto sistema di segnaletica si vede in primo luogo da come le indicazioni collocate all'esterno accolgono i visitatori. grazie alla nostra nuova gamma di signcode extern bifacciale e modulare è possibile combinare 45 formati diversi. le indicazioni bifacciali possono essere personalizzate tramite stampa diretta o laminato. le indicazioni vengono inserite nel prodotto e sono intercambiabili in qualsiasi momento. i materiali sono di alta qualità e adatti all'uso esterno. grazie alle nostre speciali basi, signcode extern avrà un grande successo anche negli spazi interni.

DE | zu einem perfekten wegleitsystem gehört bereits der empfang im aussenbereich. mit unserem doppelseitigem flexiblen signcode eXtern programm können sie 45 verschiedene masse kombinieren und modular gestalten. die doppelseitigen tafeln können mit direktdruck oder laminat personalisiert werden. die tafeln werden eingeschoben und sind jederzeit austauschbar. alle materialien sind hochwertig und für den aussenbereich geeegnet. aber auch im innenbereich macht signcode eXtern mit unseren speziellen basen eine gute figur.

EN | perfect signage welcomes visitors already to the outdoor area. with our double sided flexible signcode eXtern program you can combine 45 different sign sizes and design them in a modular way. the double sided signs can be customized with direct print or lamination. the signs are simply inserted and can be exchanged at anytime. all materials used are high grade and perfect for outdoor use. but also for indoors, you can use signcode eXtern with our special bases.

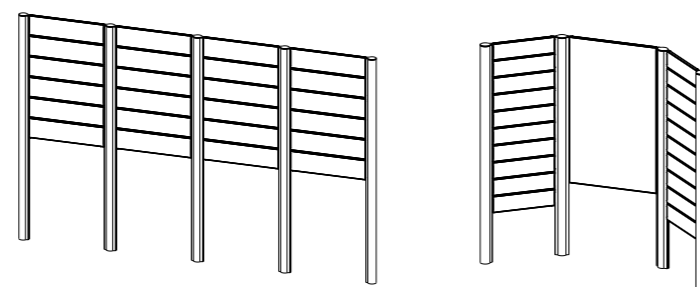

1 SIGNCODE eXtern technical details and measure on page 23

2 SIGNCODE eXtern technical details and measure on page 23

print not included

SIGN FOR

ORIENTATION



KD lays the foundation stone.
in every place the right sign.

IT | un singolo elemento oppure un sistema completo direzionale e di orientamento si adattano al cliente e si integrano nell'architettura circostante. la linea di segnaletica signcode si adatta perfettamente alle sue esigenze e offre segnaletica a soffitto, a parete, a pavimento, a bandiera e fuoriporta, così come anche segnaletica per l'esterno in diverse dimensioni, forme e colori. solo con l'aiuto di molti dettagli funzionali e creativi e con un elevato standard di qualità si ottiene da un semplice cartello un sistema di orientamento e direzionale consolidato, che porta a destinazione in sicurezza.

DE | ein einzelnes schilderelement oder auch ein komplettes leit- und orientierungssystem muss zum kunden passen und sich in die umgebende architektur eingliedern. die signcode beschilderungslinie passt sich optimal ihren bedürfnissen an und bietet decken-, fahnen-, tür- und wandschilder sowie etagenwegweiser und ausseninformation in unterschiedlichen größen, formen und farben. so machen wir aus einem schild durch die vielen funktionalen, gestalterischen details und dem hohen qualitätsstandard ein ausgereiftes orientierungs- und leitsystem, das jeden sicher an seub ziel führt.

EN | a single element or a complete directional system will adapt itself to the clients and will integrate into the surrounding architecture. the signcode range is perfectly suited to your needs and offers ceiling, wall, floor, flag and door signage, likewise for outdoor use in different dimensions, shapes and colours. only with the help of many functional and creative details and a high level of quality can you obtain from a simple sign a consolidated way finding and directional system, which takes you to the destination in safety.



1 FSOC148800AL signcode ceiling 148x800mm, 1pc

2 IP1900600ARW ipoint 1900x600 silver/white, 1pc

3 FSOS148800AL signcode suspension 148x800mm, 1pc

print not included

SIGN FOR

ORIENTATION



innovation and expressive.
a vast assortment of solutions for information, always recognizable and individual.

IT | il design della sua azienda é unico – lo deve essere anche la sua segnaletica! che si tratti di una stampa diretta sul pannello di alluminio oppure di una stampa su carta a costo contenuto, signcode ha sempre la soluzione giusta per ogni esigenza.

DE | ihr corporate design ist einzigartig - ihre beschilderung sollte es auch sein! ob brillianter direktdruck auf aluminiumpaneel oder kostengünstiger papierdruck, signcode bietet für jeden anspruch die richtige lösung.unsere signcode sind so vielfältig wie sie und ihre ansprüche.

EN | the design of your company is unique – your signage should be as well! whether it be printing directly onto an aluminium panel or onto a low cost paper sheet, signcode has the right solution for every need.

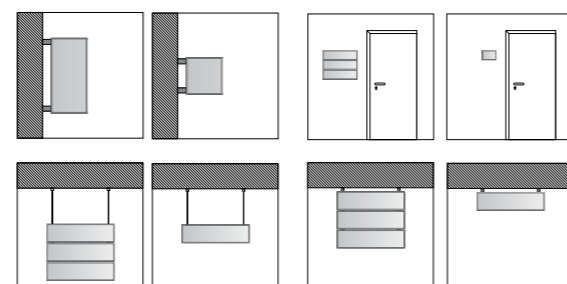

- 1 FSOS210600AL signcode suspension 210x600mm, 1 pc
- 2 FSOW297297AL signcode wall 297x297mm, 1 pc
- 3 FSOF148148AL signcode flag 148x148mm, 1 pc

print not included

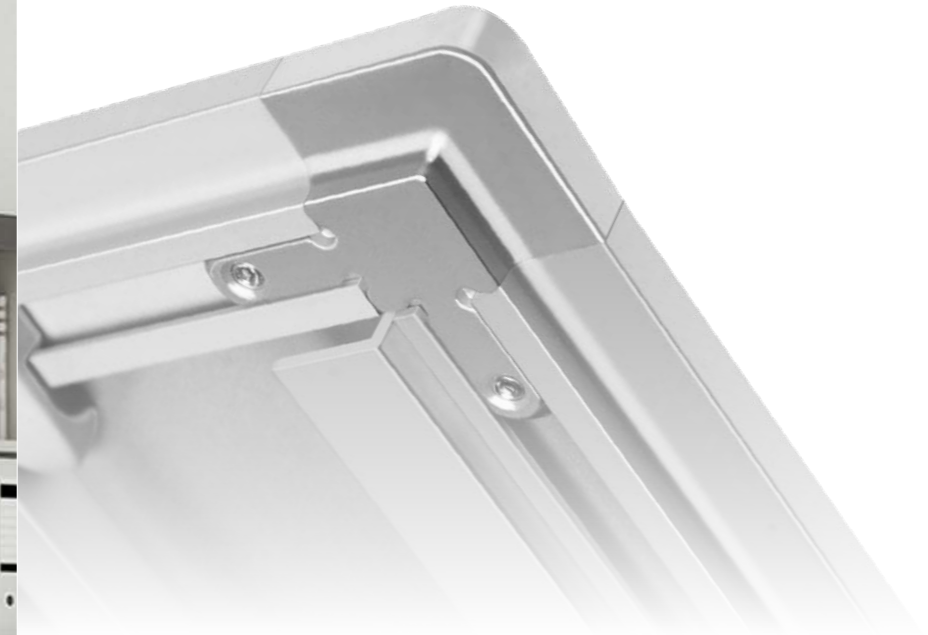

classic design par excellence.
elegant and high quality.

IT | la segnaletica del suo edificio è anche il primo biglietto da visita della sua azienda. con l'aiuto di un sistema direzionale e di orientamento, i suoi visitatori non solo saranno guidati senza deviazioni alla loro destinazione, ma anche i collaboratori apprezzeranno il design raffinato dei loro fuoriporta. Il sistema di segnaletica signcode lascia spazio alla progettazione dei suoi segnaletica. signcode è semplice, discreto, flessibile e versatile grazie alle sue possibilità quasi illimitate.

DE | die beschilderung ihres gebäudes ist auch gleichzeitig die visitenkarte ihres unternehmens. durch ein funktionierendes leit- und orientierungssystem werden ihre besucher ohne umwege zum ziel geleitet. auch ihre mitarbeiter honorieren die edle gestaltung ihrer türschilder. das signcode-leitsystem bietet viel freiraum bei der gestaltung ihrer beschilderung. es ist gradlinig, dezent und durch seine beinahe grenzenlosen möglichkeiten enorm flexibel und vielseitig.

EN | the signage on your building is, at the same time, a calling card from your company. with the help of a directional and way finding system, your visitors will not only be guided without detours to their destination, but also the employees will greatly appreciate the refined design of their door sign. the signcode signage system offers ample room for projects regarding your signage. signcode is simple, discreet, flexible and versatile thanks to it almost unlimited possibilities.



1 FSOW148148AL signcode wall 148x148mm, 1pc

2 FSOW297297AL signcode wall 297x297mm, 1pc

print not included

SIGNCODE

COLOR



color holds the message.
contrasting yet harmonious.

IT | L'innovativa segnaletica signcode colors offre un sistema direzionale a colori integrato nella cornice sui lati verticali o, nelle applicazioni a bandiera, su quelli orizzontali. oltre ai 4 colori standard della segnaletica di sicurezza, diamo la possibilità di scegliere fra ulteriori 4 colori. come già previsto dal sistema signcode, anche in questo caso sono disponibili le due versioni: con pannelli in alluminio per stampa diretta o con un protettivo trasparente in PS, che permette l'inserimento di stampe realizzate su supporto cartaceo. entrambi i sistemi sono a prova di manomissione, ma permettono comunque una semplice e veloce sostituzione delle informazioni evitando di smontare l'intera targa.

DE | das innovative beschilderungssystem signcode colors bietet exklusiv ein rahmenintegriertes farbleitsystem der vertikalen bzw. bei fahnschilder der horizontalen seiten. neben den 4 normfarben für die sicherheitsbeschilderung bieten wir ihnen weitere 4 farben zur auswahl. wie beim signcode system können sie direktbedruckte paneele verwenden oder die version mit papiereinleger hinter transparenter abdeckung. beide systeme haben einen manipulationsschutz und können dennoch jederzeit ganz einfach ohne demontage gewechselt werden.

EN | the innovative signage system signcode colors offers you a directional system with colours integrated into the frame, when used as a flag, then on the horizontal sides. over and above the 4 standard security colours, we give you the choice of a further 4 colours. just like the signcode signage you can use panels with direct print or paper print under transparent covers. both systems have a tamper-proof lock and you can change the information anytime easily without disassembling.



- 1 FSYW297297ALBL signcode colour wall 297x297mm, 1pc
 - 2 FSYF148148ALBL signcode colour flag 148x148mm, 1pc
 - 3 FSYW105210ALBL signcode colour wall 105x210mm, 1pc
- print not included

SIGNCODE

SECURE



different and coherent.
clever signcode design.

IT | segnaletica a parete completa di pittogrammi e angoli e cornici verticali del colore corrispondente al pittogramma stesso per uso interno: signcode secure offre una segnaletica completa. disponibile in quattro formati standard con pittogrammi stampati per segnaletica di evacuazione e direzione. i pittogrammi possono essere sostituiti in modo facile e veloce grazie all'intelligente sistema signcode.

DE | fertige wandbeschilderung mit sicherheitsmotiven und passender rahmenfarbkennung für den innenbereich: signcode secure hat alles schon fix fertig für sie. erhältlich in vier standardgrößen und bedruckt mit den gängigsten motiven für fluchtweg- und sicherheitsleitsysteme. die motive lassen sich dank des cleveren signcode systems jederzeit ganz einfach austauschen.

EN | ready made wall signage with security images and matching frame colours for indoor use: signcode secure has everything already for you. available in four standard sizes with prints of the most common icons for escape routes and security signage. the images can be exchanged anytime easily thanks to the clever signcode design.



- 1 FSYS210420ALGR secure suspension, 210x420mm, 1pc
 - 2 SCD148148F005 signcode secure 148x148mm, 1pc
 - 3 FRM2100 fireman, 1pc
- print not included

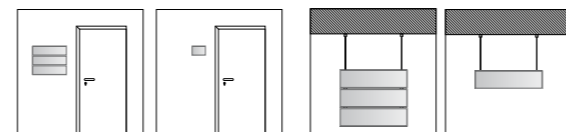

SIGNCODE

SIGNSHINE

signshine®

DIN 67510
clever design, stylish look, smart use.

IT | segnaletica di sicurezza luminescente di lunga durata unita all'intelligente sistema signcode: signshine offre una serigrafia realizzata su pvc fotoluminescente, ad alta e prolungata luminescenza. È possibile ricaricare signshine molto di frequente, è certificato per segnaletica interna e ha un'autonomia superiore alle 12 ore. offriamo misure standard per segnaletica a parete, a bandiera e a soffitto, o in alternativa anche solo i pannelli stampati con adesivo per l'applicazione. i lati colorati (le parti biadesivo rispettivamente le parti verticali per sistemi flag) sono in corrispondenza con il pittogramma scelto.

DE | nachleuchtende sicherheitsbeschilderung mit dem intelligenten signcode system: signshine bietet siebdruck auf photolumineszierendem pvc mit hoher leuchtdichte und langer nachleuchtzeit. signshine lädt sich beliebig oft auf, ist zertifiziert für raumbeschilderung und leuchtet über 12 stunden nach. wir bieten standard grössen als wand-, ausleger- oder deckenschild oder einfach nur als bedrucktes paneel zum aufkleben. bei der schildaufführung ist der vertikale rahmen - bei fahrenschild flag der horizontale - farblich auf das motiv abgestimmt.

EN | after glow security signage with the intelligent signcode system: signshine offers silk screen prints on photo luminescent pvc panels with high luminance intensity and long after glow time. signshine has unlimited reenergizing capacity, it is certified for security signage and glows in the dark more than 12 hours. we offer standard sizes as wall, flag or ceiling signs as well as the printed panel with adhesive tape. the signs come with a vertical - flag signs with horizontal - frame colour matching the icon.



- ✓ - after glow, photo luminescent panel
- according to din 67510-1 for security signs
- shows escape routes and fire extinguishers in the dark
- tested for harmful substances: cadmium free, not radioactive
- long after glow: more than 12 hours
- high luminous intensity: much higher than standards demand

	signshine		DIN 67510-1	
	10min	60min	10min	60min
after glow intensity	70	9	20	3
after glow time	>800min			
colour appearance	light yellow			
after glow colour	yellow green			

1 SSHC148297E001V28L signshine ceiling 148x297mm, 1pc



SIGNCODE

IN-OUT

SIGNCODE

BRAILLE

more than just visual.
a singular publicity means with great individuality.

IT | chiarezza a colpo d'occhio, informazione immediata, per sapere se una sala è occupata o libera... tutto ciò è possibile grazie a signcode in-out! Sposti semplicemente la targhetta in rilievo con la mano e in un attimo sarà possibile informare tutti. signcode in-out è disponibile come standard in 3 lingue, ma possibile realizzare altre varianti. contattaci per ulteriori chiarimenti.

DE | mit einem blick klarheit, ob ein raum frei ist oder belegt ist? signcode in-out macht's möglich! einfach das deckschild mit einem handgriff verschieben und schon weiss jeder bescheid. standardmässig bieten wir in-out in 3 sprachen, gerne realisieren wir auch andere motive. fragen sie uns, wir beraten sie gerne.

EN | understand immediately if a room is free or not? signcode in-out can give you that information just with one slight move by the hand. the cover is easily switched and at once everybody is informed. we provide signcode in-out in 3 different languages but also customized images are possible. please contact us directly for further details.

1 SIODE148148AL in-out, german, 148x148mm, 1pc



the dot on the "i"
we will guide you.

IT | offriamo anche una segnaletica in braille con simboli a rilievo, integrata nei nostri pannelli signcode e signcode color. per lo sfondo e per i simboli in rilievo mettiamo a disposizione vari colori. ogni realizzazione prevede una lavorazione su misura ed è quindi realizzata a richiesta in base alle sue esigenze e richieste. per ulteriori informazioni su questo prodotto esclusivo, non esiti a contattarci.

DE | beschilderung mit braille-schrift und tastbaren symbolen verwirklichen wir gerne für ihr projekt. wir verwenden dazu unsere systeme signcode oder signcode color als grundlage. für hintergrund sowie für die haptischen bereiche bieten wir diverse farben an. jedes schild ist eine einzelfertigung und wird genau nach ihrer vorgegabe gefertigt. fragen sie uns, wir beraten sie gerne persönlich.

EN | we realize also signage with braille and palpable symbols for your projects. we use our systems signcode or signcode colors as the base. for the background and the touchable areas we offer different colours. every sign is a custom made product and is made according to your design. please contact us for more details on this exclusive product.

prezzi su richiesta | preis auf anfrage | prices on demand



SIGNCODE

FIXING

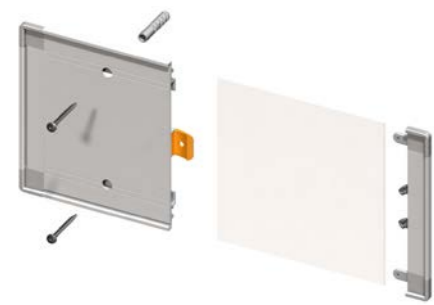

SIGNCODE® WALL

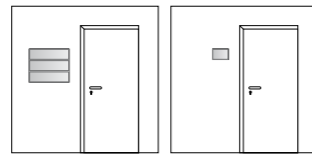

cartello a parete monofacciale, materiale per il montaggio incluso
einseitiges wandschild, montage material inkl.
single side wall sign, mounting material incl.

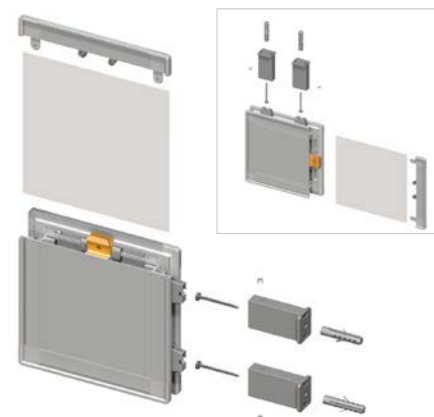

SIGNCODE® FLAG | SIGNCODE® CEILING

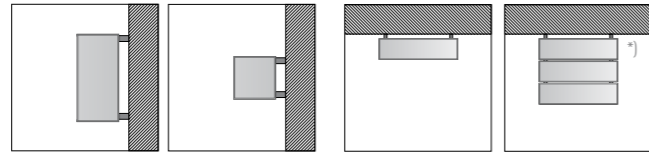

signcode flag/ceiling: cartello bifacciale, materiale per il montaggio incluso;
 *) esempio di utilizzo, su richiesta
signcode flag/ceiling: doppelseitiges auslegerschild, montage material inkl.
 *) anwendungsbeispiel auf anfrage
signcode flag/ceiling: double sided sign, mounting material incl.
 *) example of use, on request

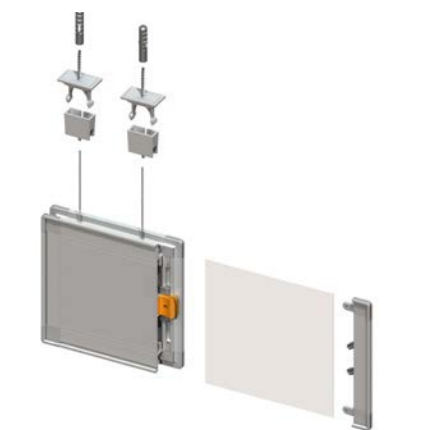

SIGNCODE® SUSPENSION

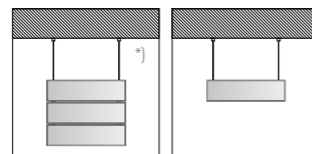

signcode suspension: sistema bifacciale sospeso su cavi di acciaio, sospensione dal soffitto variabile fino ad un massimo di 1m di distanza, materiale per il montaggio incluso *) esempio di utilizzo, su richiesta
*signcode suspension: doppelseitig für abhängung am seil, stufenlos verstellbar bis max. 1m deckenabstand, montage material inkl. *) anwendungsbeispiel auf anfrage*
signcode suspension: double-side sign for ceiling suspension, steplessly adjustable up to max. 1m ceiling distance, order extra hex key ACHI20, mounting material incl. *) example of use, on request



SIGNCODE® KEY 1)

utensile per agevolare l'apertura per il cambio delle informazioni.
 materiale: nylon stampato.
spezialwerkzeug zum einfachen öffnen für austausch der information. kunststoff-spritzguss aus nylon.
special tool for easy opening and exchange of information. injection die-casting made of nylon.

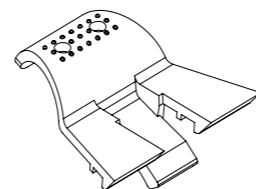

1 FSOKEY signcode key, 2pcs

1) in vendita da agosto 2013 | auslieferung ab august 2013 | on sale from august 2013

SIGNCODE

STYLE



A WITH ALUMINIUM COVER

pannello in alluminio, spessore 1,2 mm, di colore bianco RAL9016, per decorazione con pellicole adesive o per stampa diretta.

aluminium paneel 1,2mm beschichtet in RAL9016 weiss, für aufkaschieren oder direktdruck.

aluminium panel 1,2mm coated in RAL9016 white, for laminating or direct printing.



B WITH PS COVER

protettivo trasparente in PS antiriflesso, spessore 1,2 mm, per stampa su carta; sul retro può anche essere decorato con pellicole adesive o stampato direttamente

abdeckung aus 1,2mm starkem nicht reflektierendem PS, für papierdruck, kann aber auch rückseitig aufkaschiert oder direkt bedruckt werden.

cover made of 1,2mm thick non reflective PS, for paper prints, it can also be laminated or printed on the rear side.



SIGNCODE PAPER pag. 21



+ SIGNCODE® PAPER

praticità: carta prefustellata per il nostro sistema signcode, da stampare. carta opaca, 160g/m, formato a4 prefustellato a 148x148mm

praktisch: vorgestanzte einleger für unsere signcode systeme zum selber drucken: 160g/m papier weismatt in A4 format mit mittig vorgestanztem einleger 148x148mm.

convenient: preprinted paper inlay for our signcode systems for customizing with print: 160g/m paper white matt in A4 format with a center preprinted inlay of 148x148mm.

1 FSP148148 signcode paper, 148x148mm, 20pcs

INFORMATION

alluminio anodizzato color argento, tappi in metallo pressofuso color argento, A monolaterale per delimitare zone esterne, B bilaterale per posizionamento centrale

silber eloxiertes aluminium, kappen aus versilbertem metall-druckguss, A einseitig für aussenbegrenzung, B zweiseitig für mittige position

silver anodized aluminium, caps made of silver plated die-cast metal, A single sided for outside posts, B double sided for center posts

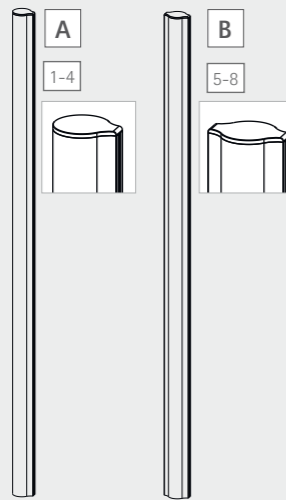

bussole da terra da avvitare su ferro zincato

bodenhülse zum festschrauben auf verzinktem eisen

ground sleeve to be screwed on, made of zincated iron

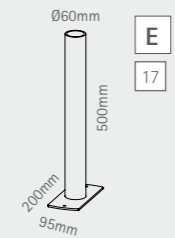

bussole da terra per calcestruzzo o fondamenta in cemento

bodenhülse für beton oder zement fundamente

ground sleeve for concrete installation

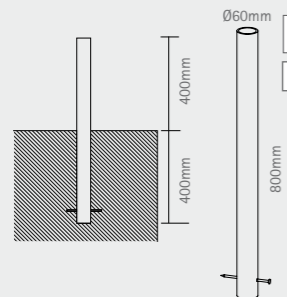

cartelli bifacciali con cornici in alluminio anodizzato color argento, angoli realizzati in metallo pressofuso satinato color argento, lastra in alluminio con rivestimento bianco

doppelseitige tafeln mit silber eloxiertem aluminium profilrahmen, matt versilberten metall druckguss ecken, aluminium platten weiss beschichtet

double sided signs with silver anodized aluminium frame, matt silver plated die-cast metal corner connectors, aluminium panels with white coating

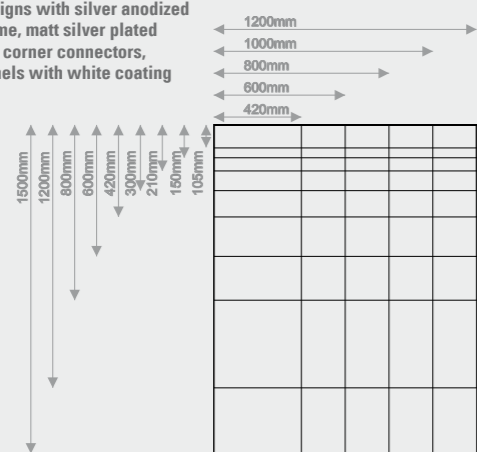

INFORMATION

alluminio anodizzato color argento, tappi in metallo pressofuso color argento, D monolaterale per delimitare zone esterne, C bilaterale per posizionamento centrale. Solo per spazi interni

silber eloxiertes aluminium, kappen aus versilbertem metall-druckguss, D einseitig für aussenbegrenzung, C zweiseitig für mittige position. nur für innenbereich.

silver anodized aluminium, caps made of silver plated die-cast metal, D single sided for outside posts, C double sided for center posts. only for indoor use.

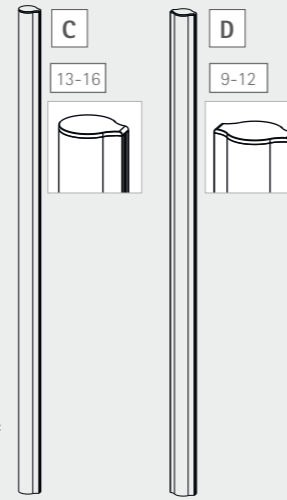

rivestimento di protezione in abs color grigio chiaro, con piastra di metallo, piede solo per uso interno

lichtgraue abs abdeckung mit gewichtsplatte, standfuss nur für innenbereich.

light grey abs cover with weight plate, base only for indoors.

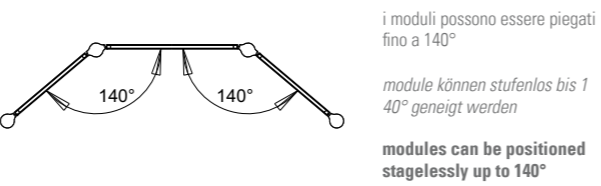
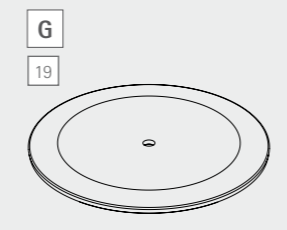

FIRMLY MOUNTED

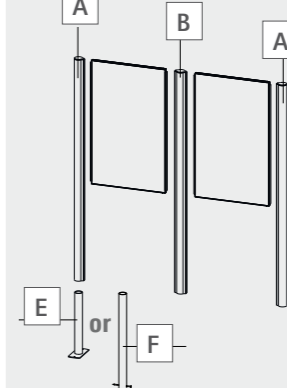

combini a piacimento tubi e basi da terra corrispondenti

kombinieren sie posten und entsprechende bodenhalterungen

choose these posts with the needed ground sleeves

FREE STANDING INDOORS

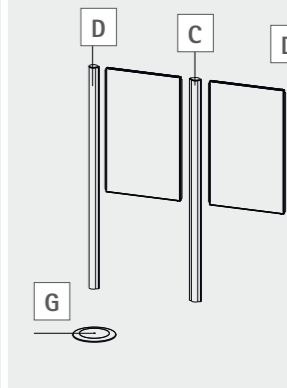

è possibile combinare i pali per spazi interni con basi circolari

kombinieren sie für den innenbereich diese posten mit runden fussplatten

choose these posts with round floor bases for indoor use

SIGNCODE® eXtern 1)

1	SCXPAV1200	post A 1200mm, 2pcs	33	SCX2101000	signcode extern 210x1000mm, 1pc
2	SCXPAV1500	post A 1500mm, 2pcs	34	SCX2101200	signcode extern 210x1200mm, 1pc
3	SCXPAV1800	post A 1800mm, 2pcs	35	SCX300420	signcode extern 300x420mm, 1pc
4	SCXPAV2000	post A 2000mm, 2pcs	36	SCX300600	signcode extern 300x600mm, 1pc
5	SCXPMV1200	post B 1200mm, 1pc	37	SCX300800	signcode extern 300x800mm, 1pc
6	SCXPMV1500	post B 1500mm, 1pc	38	SCX3001000	signcode extern 300x1000mm, 1pc
7	SCXPMV1800	post B 1800mm, 1pc	39	SCX3001200	signcode extern 300x1200mm, 1pc
8	SCXPMV2000	post B 2000mm, 1pc	40	SCX420420	signcode extern 420x420mm, 1pc
9	SCXPMM1200	post C 1200mm, 1pc	41	SCX420600	signcode extern 420x600mm, 1pc
10	SCXPMM1500	post C 1500mm, 1pc	42	SCX420800	signcode extern 420x800mm, 1pc
11	SCXPMM1800	post C 1800mm, 1pc	43	SCX4201000	signcode extern 420x1000mm, 1pc
12	SCXPMM2000	post C 2000mm, 1pc	44	SCX4201200	signcode extern 420x1200mm, 1pc
13	SCXPAM1200	post D 1200mm, 2pcs	45	SCX600420	signcode extern 600x420mm, 1pc
14	SCXPAM1500	post D 1500mm, 2pcs	46	SCX600600	signcode extern 600x600mm, 1pc
15	SCXPAM1800	post D 1800mm, 2pcs	47	SCX600800	signcode extern 600x800mm, 1pc
16	SCXPAM2000	post D 2000mm, 2pcs	48	SCX6001000	signcode extern 600x1000mm, 1pc
17	SCXFLOOR	ground sleeve E, 1pc	49	SCX6001200	signcode extern 600x1200mm, 1pc
18	SCXGROUND	ground sleeve F, 1pc	50	SCX800420	signcode extern 800x420mm, 1pc
19	SCXBAR	base for indoors, 1pc	51	SCX800600	signcode extern 800x600mm, 1pc
20	SCX105420	signcode extern 105x420mm, 1pc	52	SCX800800	signcode extern 800x800mm, 1pc
21	SCX105600	signcode extern 105x600mm, 1pc	53	SCX8001000	signcode extern 800x1000mm, 1pc
22	SCX105800	signcode extern 105x800mm, 1pc	54	SCX8001200	signcode extern 800x1200mm, 1pc
23	SCX1051000	signcode extern 105x1000mm, 1pc	55	SCX1200420	signcode extern 1200x420mm, 1pc
24	SCX1051200	signcode extern 105x1200mm, 1pc	56	SCX1200600	signcode extern 1200x600mm, 1pc
25	SCX150420	signcode extern 150x420mm, 1pc	57	SCX1200800	signcode extern 1200x800mm, 1pc
26	SCX150600	signcode extern 150x600mm, 1pc	58	SCX12001000	signcode extern 1200x1000mm, 1pc
27	SCX150800	signcode extern 150x800mm, 1pc	59	SCX12001200	signcode extern 1200x1200mm, 1pc
28	SCX1501000	signcode extern 150x1000mm, 1pc	60	SCX1500420	signcode extern 1500x420mm, 1pc
29	SCX1501200	signcode extern 150x1200mm, 1pc	61	SCX1500600	signcode extern 1500x600mm, 1pc
30	SCX210420	signcode extern 210x420mm, 1pc	62	SCX1500800	signcode extern 1500x800mm, 1pc
31	SCX210600	signcode extern 210x600mm, 1pc	63	SCX15001000	signcode extern 1500x1000mm, 1pc
32	SCX210800	signcode extern 210x800mm, 1pc	64	SCX15001200	signcode extern 1500x1200mm, 1pc

1) in vendita da settembre 2013 | auslieferung ab september 2013 | on sale from september 2013

NEW STANDARD ISO EN 7010

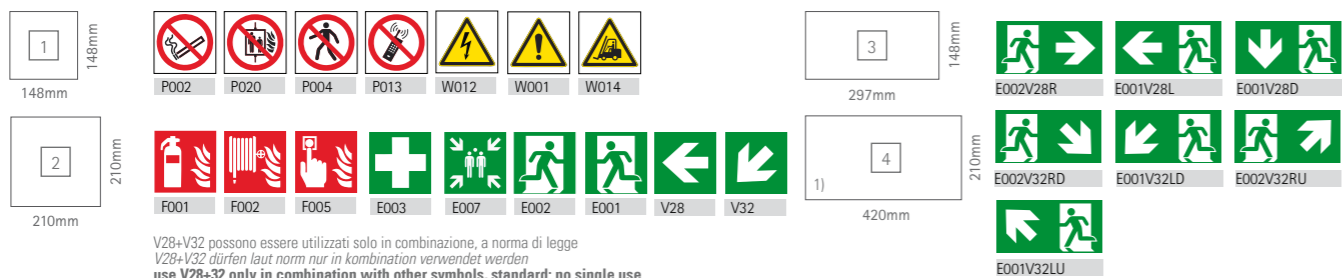

V28+V32 possono essere utilizzati solo in combinazione, a norma di legge
V28+V32 dürfen laut norm nur in kombination verwendet werden
use V28+32 only in combination with other symbols, standard: no single use

1) formato non adatto per signcode flag | gröÙe nicht für flag geeignet | not suitable format for signcode flag

SIGNCODE® SECURE

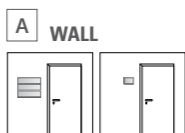

1	SCD148148	*	secure wall, 148x148mm, 1pc
2	SCD210210	*	secure wall, 210x210mm, 1pc
3	SCD148297	*	secure wall, 148x297mm, 1pc
4	SCD210420	*	secure wall, 210x420mm, 1pc

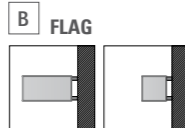

1	SCDF148148	*	secure flag, 148x148mm, 1pc
2	SCDF210210	*	secure flag, 210x210mm, 1pc
3	SCDF148297	*	secure flag, 148x297mm, 1pc

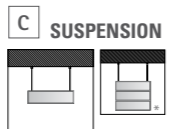

1	SCDS148148	*	secure suspension, 148x148mm, 1pc
2	SCDS210210	*	secure suspension, 210x210mm, 1pc
3	SCDS148297	*	secure suspension, 148x297mm, 1pc
4	SCDS210420	*	secure suspension, 210x420mm, 1pc

* application on demand

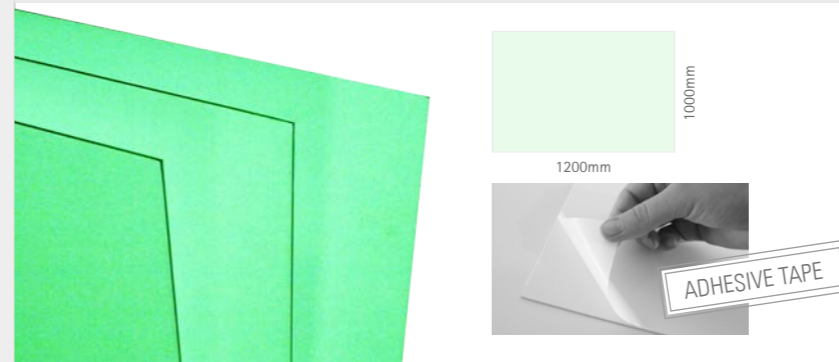

pannello fotoluminescente ad alta autonomia da personalizzare tramite stampa serigrafica o inchiostro solvente; spessore 1,2mm pannello rigido biadesivo in pvc

nachleuchtendes paneel zum selbst bedrucken mit siebdruck oder solvent ink. 1,2mm stark, mit doppelklebefolie, pvc hartplatte

photo luminescent panel can be printed with silk screen or solvent ink. 1,2mm thick, with double adhesive tape, pvc rigid panel

SIGNSHINE® PANEL

1	SSH12001000	signcode panel, 1200x1000mm, 1pc
---	-------------	----------------------------------

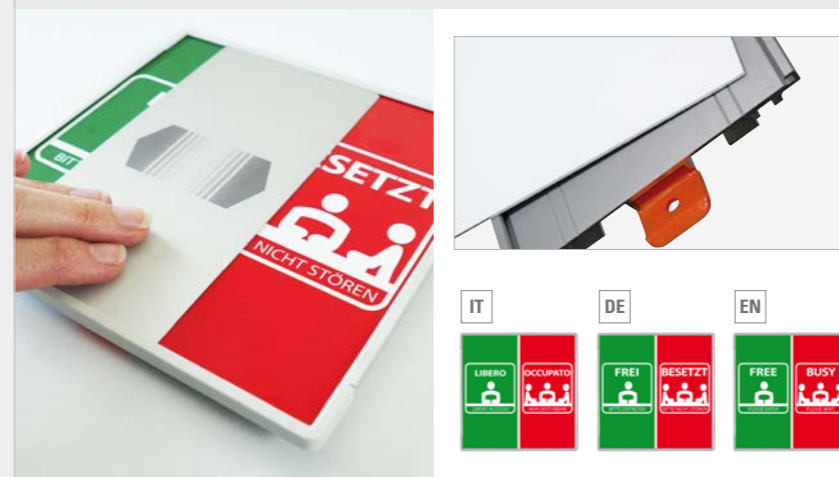

alluminio anodizzato color argento, parti laterali color grigio chiaro realizzate in materiale sintetico, stampa diretta tramite il sistema printolux

silber eloxiertes aluminium, lichtgraue kunststoff seiten, direktdruck mit printolux system

silver anodized aluminium, light grey synthetic lateral parts, direct print with printolux system

SIGNCODE® IN-OUT

2	SIOIT148148AL	in-out, italian, 148x148mm, 1pc
3	SIODE148148AL	in-out, german, 148x148mm, 1pc
4	SIOEN148148AL	in-out, english, 148x148mm, 1pc

NEW STANDARD ISO EN 7010

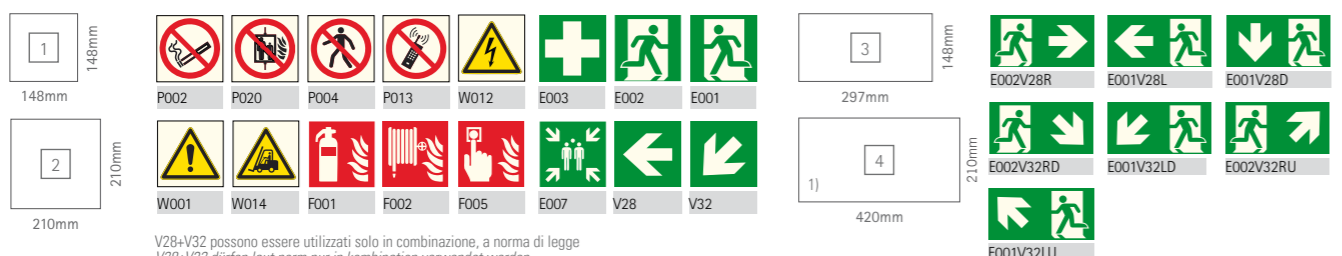

V28+V32 possono essere utilizzati solo in combinazione, a norma di legge
V28+V32 dürfen laut norm nur in kombination verwendet werden
use V28+32 only in combination with other symbols, standard: no single use

1) formato non adatto per signcode flag | gröÙe nicht für flag geeignet | not suitable format for signcode flag

SIGNSHINE® COMPLETE

1	SSHW148148	*	wall 148x148mm, 1pc
2	SSHW210210	*	wall 210x210mm, 1pc
3	SSHW148297	*	wall 148x297mm, 1pc
4	SSHW210420	*	wall 210x420mm, 1pc

1	SSHF148148	*	flag 148x148mm, 1pc
2	SSHF210210	*	flag 210x210mm, 1pc
3	SSHF148297	*	flag 148x297mm, 1pc

1	SSHC148148	*	ceiling 148x148mm, 1pc
2	SSHC210210	*	ceiling 210x210mm, 1pc
3	SSHC148297	*	ceiling 148x297mm, 1pc
4	SSHC210420	*	ceiling 210x420mm, 1pc

1	SSHS148148	*	suspension 148x148mm, 1pc
2	SSHS210210	*	suspension 210x210mm, 1pc
3	SSHS148297	*	suspension 148x297mm, 1pc
4	SSHS210420	*	suspension 210x420mm, 1pc

* application on demand

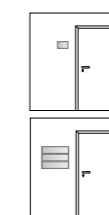

sistema di orientamento con scritte in braille. dai fuoriorpota agli indicatori di direzione con scrittura puntiforme. produciamo esattamente le sue esigenze. realizziamo anche su progetto.

schilder-leitsysteme mit braille schrift, vom barrierefreien türschild bis zum wegweiser mit tastbarer schrift und symbolik. wir fertigen genau nach ihren wunschen und vorstellungen. fragen sie uns, wir beraten sie gerne.

way finding system with braille. from door signs to directional indications with tactile characters. we produce exactly to your requirements. we can also undertake projects.

SIGNCODE® BRAILLE

prezzi e misure su richiesta | preis und maÙe auf anfrage | prices and sizes on demand



MORE IDEAS FOR INDIVIDUAL SIGN

be inspired also by all of our products which adapt themselves perfectly to our signage assortment.



IDEAS

CREATIVE SIGNAGE

MAGINFO SLIM

freestanding floor display with modern design.

IT | un display autoportante con due funzioni: presentazione di informazioni e portacataloghi. il poster può essere cambiato velocemente grazie alle strisce magnetiche che mantengono in posizione il foglio protettivo anti-riflesso. i due ripiani in materiale acrilico sono l'ideale per brochure in formato A4 e flyers. tutti i materiali sono di alta qualità e di lunga durata. il suo maginfo slim farà della sua presentazione un successo a lungo termine!

DE | ein freistehendes bodendisplay mit doppelfunktion: poster-präsentation und katalog-dispenser. die poster-info kann jederzeit schnell gewechselt werden und die magnetstreifen halten die reflektionsarme abdeckung sicher fest. die beiden ablagen aus satiniertem acrylglas bieten platz für kataloge oder flyer in A4. alle materialien sind hochwertig und langlebig, so dass sie an ihrem maginfo slim lange freude haben.

EN | freestanding floor display with a double use: poster presentation and catalogue dispenser. the poster can be exchanged quickly at anytime as the magnetic tapes keep the non-reflective transparent cover safely in place. the two trays made of satin acrylic are best for A4 brochures and flyers. all materials are high-grade and long living. your maginfo slim will make your presentation a long-term success.

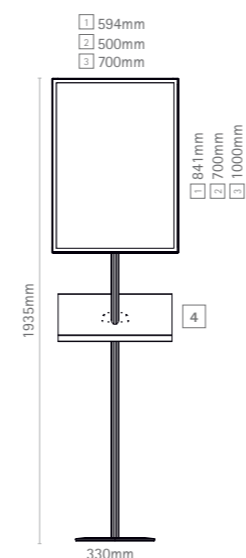
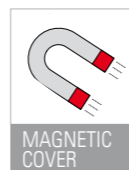
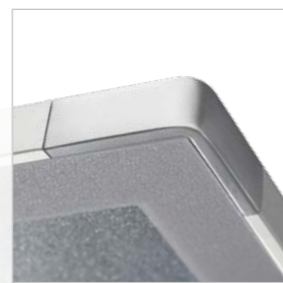

MAGINFO SLIM

1	SOMSA1	maginfo slim A1, 1pc
2	SOMS700500	maginfo slim 700x500mm, 1pc
3	SOMS1000700	maginfo slim 1000x700mm, 1pc

ripiano da ordinare separatamente | ablage extra bestellen | order brochure shelf extra

4	SOTR2A4TR	tray 2 A4 V, 1pc
---	-----------	------------------

MONOFRAME

attractive, but at the same time simple and elegant.

IT | il monoframe è la soluzione perfetta per la decorazione e l'allestimento delle pareti grazie alla stampa di alta qualità su tessuto. il design discreto della cornice lascia l'immagine in primo piano. l'alluminio anodizzato color argento e gli angoli realizzati in metallo pressofuso garantiscono una lunga durata del prodotto. grazie alle strisce in silicone cucite sul tessuto la sostituzione dello stesso potrà avvenire in qualsiasi momento in modo facile, veloce e senza l'utilizzo di utensili.

DE | monoframe ist die perfekte lösung für die dekorative wandgestaltung mit ihrem hochwertigem textildruck. ein schlankes design lässt den rahmen dezent in den hintergrund treten. das motiv steht im vordergrund. hochwertige materialien wie silber eloxiertes aluminium und metall-druckguss-ecken garantieren lange freude an diesem system. der textile banner wird dank der flachkeder schnell und einfach befestigt. so ist auch der austausch ohne demontage und werkzeug im nu erledigt.

EN | monoframe is the perfect solution for your decorative wall elements with your high-grade print on fabric. a lean design keeps the frame in the background, while the image is in the center of attention. high-quality materials as silver anodized aluminium and die-cast metal corner connectors guarantee a long lifetime. the textile banner is easily mounted thanks to the silicone strips. thus the exchange is quick and easy without any tools anytime.

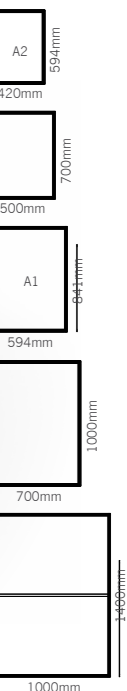

MONOFRAME

1	MFRA2	monoframe A2, 1pc
2	MFR700500	monoframe 700x500mm, 1pc
3	MFRA1	monoframe A1, 1pc
4	MFR1000700	monoframe1000x700mm, 1pc
5	MFR1400100	monoframe1400x1000mm, 1pc

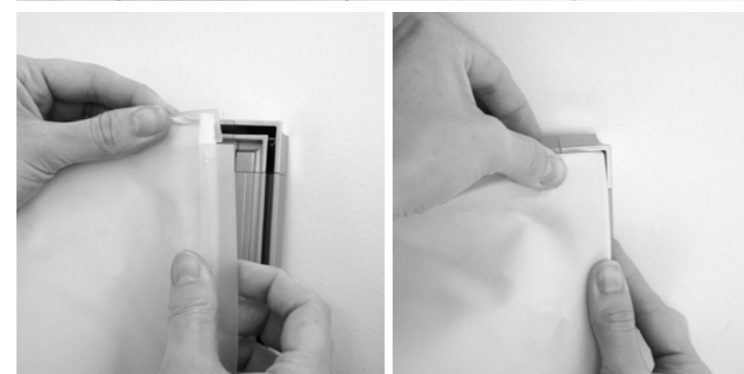

IDEAS

IPOINT MEDIA

unbeatable and discreet.

IT | ipoint media per presentazioni audiovisive attira l'attenzione con il suo look elegante in nero e gli schermi da 12.1" o 17". potrà completare il suo ipoint media anche con ripiani o barre laterali. ci comunichi già al momento dell'ordine quali accessori desidera, così da poterlo predisporre già in fase di produzione. per motivi tecnici di produzione, l'allestimento di ipoint media con ulteriori accessori non è possibile dopo l'assemblaggio.

DE | ipoint media für die audiovisuelle präsentation in elegantem schwarz begeistert durch 12.1" bzw. 17" lcd schirm. optional statten wir die ipoints mit prospekt ablagen oder display bars aus. einfach bei bestellung mitteilen, welche optionals sie wünschen. unsere produktion wird dies bei der montage entsprechend vorsehen. ein nachrüsten ist aus montagetechnischen gründen nicht möglich.

EN | ipoint media for the audiovisual presentation wows you and your customers with its elegant look and the 12.1" resp. 17" screens. optional the ipoint media can be upgraded with brochure trays or display bars. let us know with your order which options you like. we will prepare your ipoint accordingly. due to production-related reasons it is not possible to upgrade the ipoint media after assembling.

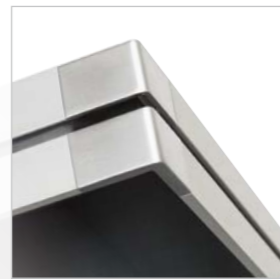

sul retro si trova l'interfaccia per la memory card o usb e l'uscita per il cavo
auf der rückseite befindet sich die schnittstelle für memory card oder usb sowie der kabelausgang

on the rear side you find the interfaces for memory card or usb and the exit of the cable.



1 480mm
2 550mm



IPOINT MEDIA

1	IPM12	ipoint media 12.1", 1pc
2	IPM17	ipoint media 17", 1pc

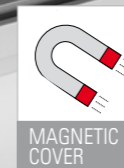

MULTIMEDIA

LUMO

a very slim and modern light panel.

IT | elegante e sottile, ecco come si presenta il pannello retroilluminato della linea lumo. cambio rapido delle informazioni o immagini grazie al foglio protettivo flessibile dotato di strisce magnetiche. l'illuminazione a led a lunga durata garantisce un'illuminazione uniforme dagli angoli fino al centro, mettendo in risalto le sue immagini.

DE | ganz schlank und edel präsentiert sich der leuchtrahmen lumo. schnell lässt sich ihr bild oder die info auswechseln, dank der flexiblen coverfolie mit magnetstreifen. die ausleuchtung ist perfekt bis ins zentrum und die langlebigen led schaffen mit ihren bildern eine ganz besondere atmosphäre.

EN | very slim and elegant is the light panel from the lumo series. quick exchange of the information or decorative image thanks to the flexible transparent cover foil held by magnetic strips. the illumination is perfectly uniform from edge to center and the long life led makes your images a very special eye catcher.

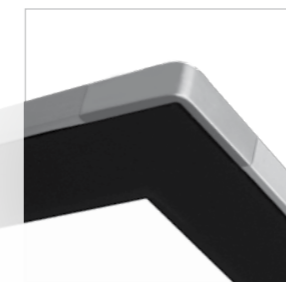

led-lights

presentazione eccellente con luci led di qualità: 240led/m

brillante präsentation mit hochwertigen led-leuchten: 240led/m

brilliant presentation with first choice led-lights: 240led/m

LUMO

1	LUMORA4	lumo A4, 1pc
2	LUMORA3	lumo A3, 1pc
3	LUMOR700500	lumo 700x500mm, 1pc
4	LUMORA1	lumo A1, 1pc
5	LUMOR1000700	lumo 1000x700mm, 1pc

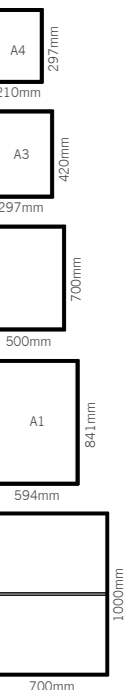

BROCHURE DISPLAY

DACAPO IPOINT

pivots for perfect functioning and quality.

IT | design semplice e moderno da ora anche flessibile: è sufficiente agganciare le tasche trasparenti al display bifacciale nero opaco con cornice argentata e il gioco è fatto. sono disponibili tasche in 3 diversi formati: A4, A5 e A6. display da terra bifacciale autoportante. cornice in alluminio anodizzato color argento, pannello in alu bond color nero, base color nero opaco.

DE | schlankes, modernes design und äusserst flexibel: in das doppelseitige schwarzmatte display mit den silbermatten seiten werden die transparenten container einfach ein-, aus- und umgehängt. container für format A4, A5 und A6 stehen für sie zur auswahl bereit. doppelseitiges freistehendes bodendisplay: silbereloxierter alu-rahmen, schwarzes alu-verbundpaneel, schwarz-matte basis

EN | lean and modern design yet very flexible: simply insert into the double side black matt display with silver matt frame the transparent containers. we have containers in A4, A5 and A6 sizes for you to choose from. double-side freestanding floordisplay: silver anodized aluminium frame, black aluminium composite panel, black matt base.

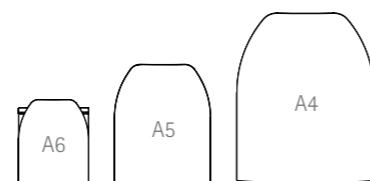

DACAPO IPOINT

1	DCI1730250SZ	dacapo ipoint black, 1pc
2	DCTA6	brochure pocket A6, 1pc
3	DCTA5	brochure pocket A5, 1pc
4	DCTA4	brochure pocket A4, 1pc

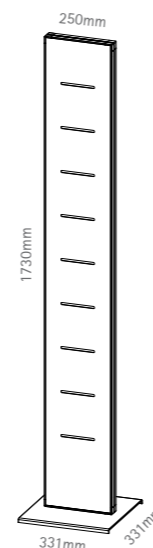

I NOSTRI PRODOTTI | UNSERE PRODUKTE | OUR PRODUCTS

ZIP

presentazione & portadepliant
präsentation & prospektständer
presentation & brochure holders



DIGI

sistemi espositivi
displays & werbeträger
digital print displays



FLY

presentazione su cavi e astine
stab- und seilspannsysteme
suspension systems



FISSO

targhe & fissaggi
befestigungen & schilder
signs & fixings



SHOP

allestimento & arredamento
ladenbau & einrichtung
shop fitting & interiors

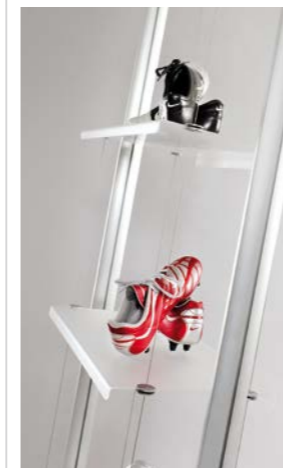

tutto e ancor di più per l' allestimento di negozi e per eventi: mobili completi, accessori e complementi modulari per l'arredo e l'allestimento creativo.

alles für die komplettausstattung von shops wie events: fertiges mobilier, zubehör und modulare komponenten für die ganz individuelle einrichtung und den kreativen ladenbau.

all for the complete fitting of shops and events: ready to use furniture, accessories and modular components for very individual interiors and the creative shop fitters.

ALTRI CATALOGHI | WEITERE KATALOGE | OTHER CATALOGS



CHI SIAMO

IT | K-D è fabbrica di design, atelier di idee e luogo di mercato situata sulle alpi meridionali. luogo ideale per designer e artisti, vi si incontrano anche commerciali ed esperti di mercato. le prime strabilianti idee si sono convertite oggi in una vasta e completa gamma di soluzioni standard per il punto vendita, lo showroom, l'ufficio e la casa. il nostro fiuto per i trend ci spinge verso il domani: soluzioni e prodotti artistici (kunst) – che siano fertilizzante (dünger) per i nostri clienti. abbiamo tante altre idee: contattateci e saremo lieti di consigliarvi sempre al meglio!

ÜBER UNS

DE | K-D ist designfabrik, ideenatelier und marktplatz auf der alpensüdseite. ein ort für designer, künstler und vermarkter. clevere produktideen haben sich zu einer breiten palette an bewährten standardlösungen für point of sale, showroom, office und homebereich entwickelt. mit gespür für trends sorgen wir so für morgen: produktlösungen mit „kunst“ - „dünger“ für unsere kunden. fragen sie uns wir haben viele ideen und beraten sie gerne!

ABOUT US

EN | K-D today is a design factory, idea studio and market place in northern italy. a place for designers, artists and marketing. clever product ideas have grown into a large range of proven and tested standard solutions for point of sale, showroom and office. with a sense for trends we provide for the future product solutions with “art” (=kunst) bringing “fertiliser” (=dünger) to the business of our customers. we have many ideas for you. contact us and we will be happy to assist you!

salvo errori ed omissioni. ci riserviamo di apportare modifiche tecniche ai prodotti, senza preavviso.

fehler, - und technische änderungen vorbehalten.

errors and omissions excepted. we reserve the right to effect product technical modifications without prior notice.



comunicazione visiva
visuelle kommunikation
visual communication



espositori & displays
digitaldruck- und prospektdisplays
digital printing & brochure displays



sistemi guidalinee
personenleitsysteme
crowd control

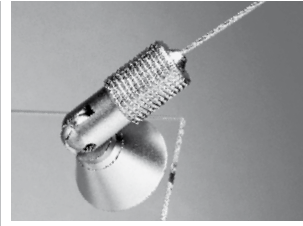

sistemi espositivi su cavi
spannseil präsentationssysteme
suspension information systems

